



Accurate Calibration of Frequency

By Staffan Johansson (Pendulum Instruments AB)

The concept of *calibration* implies the comparison of a DUT (Device Under Test) parameter (the unknown quantity) with a standard (the known quantity) and documentation of the difference. Moreover, the concept of *adjustment* implies that we affect the DUT in such a way that the difference between the controlled value and the desired value will decrease. Consequently we need a *reference* and a *comparator* to perform a calibration. See Figure 1.

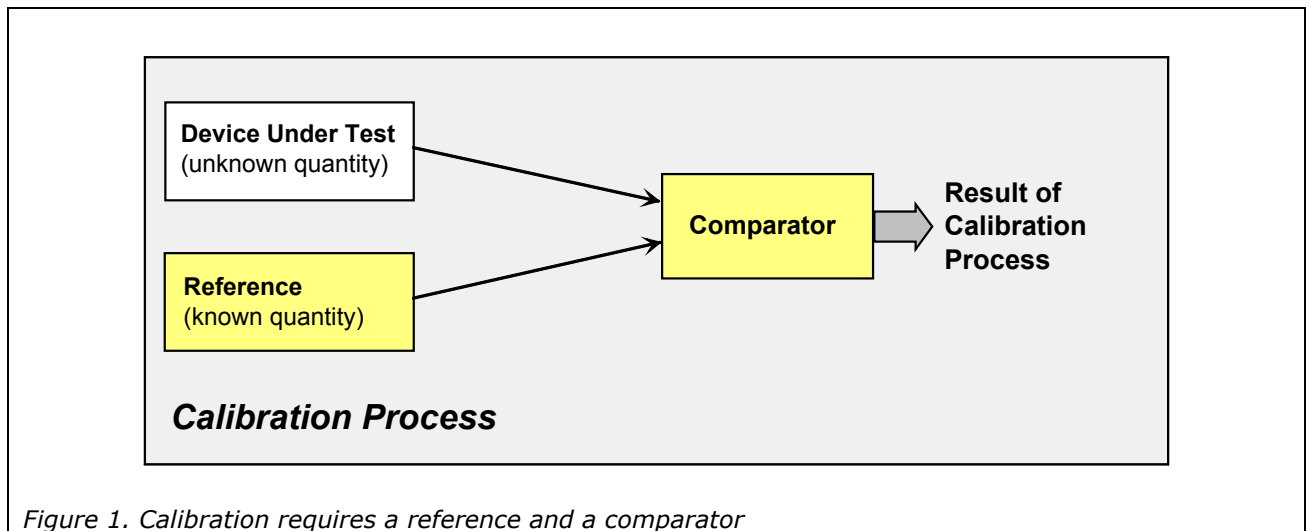

Figure 1. Calibration requires a reference and a comparator

Especially for *frequency calibration* we mainly use a *frequency counter*, characterized by the fact that it contains the frequency reference (a 10 MHz timebase oscillator) as well as the comparator. See Figure 2. However, most counters can accommodate an external reference, if necessary.

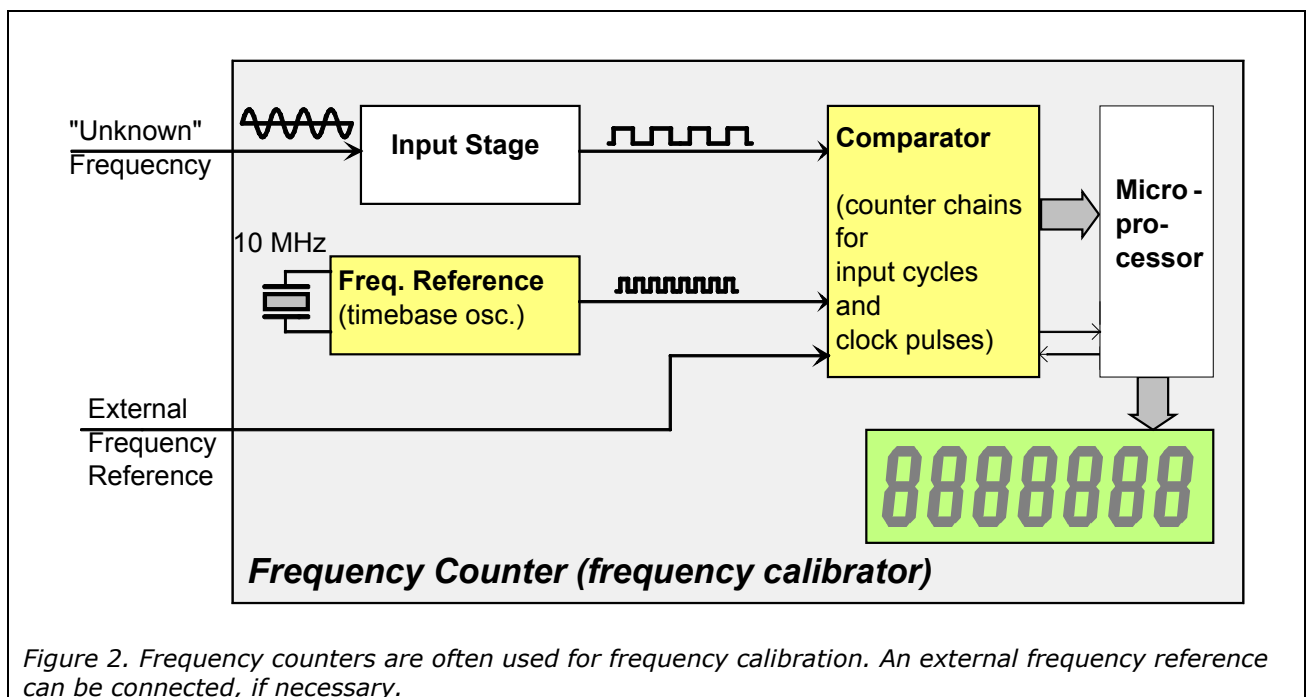

Figure 2. Frequency counters are often used for frequency calibration. An external frequency reference can be connected, if necessary.



There are two basic methods for frequency calibration, *direct frequency measurement* and *phase comparison*.

Direct Frequency Measurement

The normal method of frequency calibration is simply to connect a frequency counter to the DUT and read the result. See Figure 2 again.

The advantage of this method is that we can calibrate an arbitrary frequency within the frequency range of the counter (typically from mHz to GHz). The disadvantage is that the accuracy of the measurement is limited to approximately 10 digits, even with the counters having the highest resolution on the market and built-in atomic clock (Rubidium reference).

Measurement Uncertainty:

What measurement uncertainty can we expect? The most important factors to consider are the counter's *timebase oscillator* and *resolution*, see Basics in Brief. Then we must add *trigger error* due to signal noise and/or internal noise, and *systematic timing error* in the counting circuits. The latter sources of errors are usually negligible compared to the former and normally appear in the 9th – 10th digit of the result.

According to the theories of uncertainty calculation, we should calculate the total uncertainty using the following steps:

1. Compensate the result for known systematic errors.
2. Express all the remaining uncertainty factors as standard deviation ("rms value" or "1 sigma value").
3. Add up the squares of all uncertainties to be considered and extract the square root of the sum. This will give us a standard uncertainty "rms" (rms = root mean square).
4. Reduce the risk of a measurement value being outside the area of uncertainty by multiplying the standard uncertainty (from step 3) by 2. For a normal distribution, 96 % of all measurements will be within the given area of uncertainty.
5. If, for instance, both resolution and timebase uncertainty are 1×10^{-7} (rms), and the other sources of errors are negligible, then the total uncertainty will be:

$$2 \times \sqrt{1^2 + 1^2} \times 10^{-7} \approx 3 \times 10^{-7}$$

Modern counters have a resolution of typically 9-10 digits, and in certain cases up to 11 digits, for a measuring time of 1 s. It is the built-in timebase oscillator that limits the accuracy to 5-10 digits, depending on the type of timebase oscillator used (Standard/TCXO/OCXO/Rubidium).

Theoretically we can use an external Cesium standard or a GPS-controlled Rubidium reference to obtain measurement results with 11-12 digits, but it is not sufficient in practice for the counter to attain a total uncertainty on this level of accuracy. The systematic error of the counter usually puts an end to improvement at 9-10 digits.



Even with the best instruments on the market (e. g. CNT-81 from Pendulum) we cannot get beyond a measurement uncertainty in the 10th digit when using direct frequency measurement. If we want to make frequency measurements with an uncertainty only in the 11th, 12th or 13th digit, we have to turn to *phase comparison*.

Phase Comparison (TIE Method)

By means of phase comparison we can compare the phase difference of two signals having the *same* nominal frequency. One signal is the reference with "known" frequency and the other signal comes from the DUT, the "unknown" frequency. By measuring how fast the phase difference increases or decreases, we can estimate the frequency difference between the signals.

We can make an analogous comparison to tuning a musical instrument. A guitar string, for instance, is best "calibrated" by simultaneously plucking two strings of the same pitch (the "reference" and the one to be tuned). One listens to the beat frequency created by the two strings and adjusts one string (the DUT) until the beat frequency ceases (the change of phase approaches zero). The beat method (phase comparison) gives the tuning quite a different precision compared to listening to just one string and trying to put its absolute frequency in tune (direct frequency measurement).

The easiest way to estimate the phase difference between the reference and the DUT is to measure the time interval between the zero crossings of the signals by means of a timer/counter. This time interval is usually called TIE (Time Interval Error), see Figure 3.

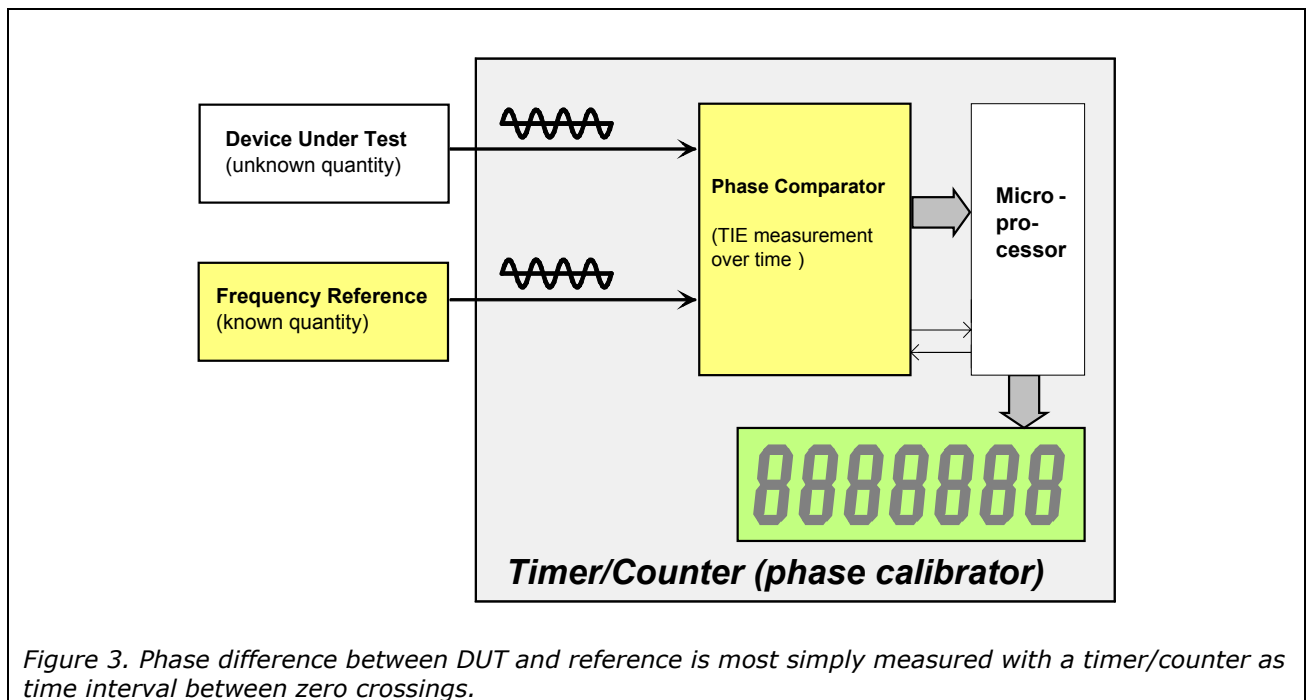
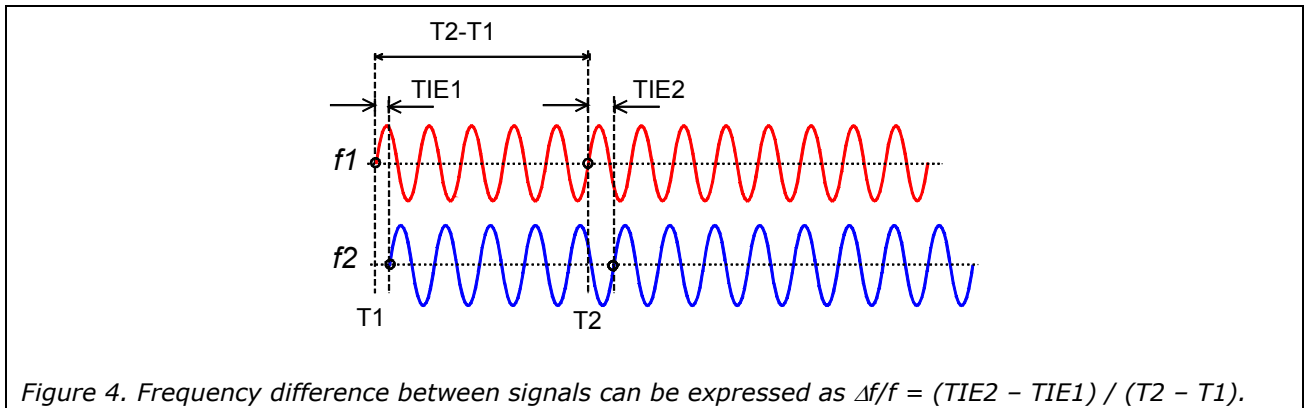

Figure 3. Phase difference between DUT and reference is most simply measured with a timer/counter as time interval between zero crossings.



The relative frequency difference between the signals in Figure 4 will then be:

$$\frac{\Delta f}{f} = \frac{TIE2 - TIE1}{T2 - T1}$$



The uncertainty of a single TIE measurement is partly the resolution, partly a systematic error that can be up to one nanosecond (or more in certain models) if we have an uncalibrated input on the timer/counter. As we take the difference between two TIE measurements at different points of time, all systematic sources of error will be eliminated, since these errors are subtracted from themselves.

With an accurate frequency reference and a high-resolution time interval meter (timer/counter) we can attain uncertainties of 10^{-12} or better.

Let us give an example. We are measuring the frequency difference between an unknown 10 MHz signal and an extremely stable 10 MHz reference from the GPS-controlled frequency reference GPS-89 with a built-in Rubidium oscillator. A CNT-81 with 50 ps resolution is being used for the time interval measurement. We are measuring the time interval between the zero crossings of the signals every 20 seconds and get the following measurement results.

Time (T)	TIE	$\Delta(TIE)$	$\Delta(f)$
T0=0s	+4.55 ns		
T1=20s	+4.75 ns	200 ps	200ps/20s = $1,0 \times 10^{-11}$
T2=40s	+4.99 ns	440 ps	440ps/40s = $1,1 \times 10^{-11}$
T3=60s	+5,23 ns	680 ps	680ps/60s = $1,1 \times 10^{-11}$
T4=80s	+5,49 ns	940 ps	940ps/80s = $1,2 \times 10^{-11}$
T5=100s	+5,72 ns	1170 ps	1170ps/100s = $1,2 \times 10^{-11}$

In this example we can draw attention to the fact that after 100 s the two compared frequencies differ by 1.2×10^{-11} . After only 20 seconds we get a very good measure of the difference.



Measurement Uncertainty

What is the uncertainty of this measurement? The CNT-81 measures time interval (TIE) with 50 ps resolution and point of time (T) with 100 ns resolution. In this example we have a TIE uncertainty at time T0 and T5 resp. of 50 ps, plus the same systematic error in both TIE measurements. The uncertainty of the time difference T5-T0 (100 ns in 100 s) is negligible. Since we subtract TIE(T0) from TIE(T5) the systematic error will be completely eliminated and only the uncertainty of the resolution will remain. The total uncertainty is calculated as before as "the double rms value" of the relevant uncertainty factors, and we get in this case:

$$\frac{2 \times \sqrt{(50\text{ps})^2 + (50\text{ps})^2}}{100\text{s}} \approx 1,4 \cdot 10^{-12}$$

Note that the uncertainty in the example refers to how accurately we can measure the *difference* between the two frequencies. In order to draw conclusions as to the accuracy of the DUT frequency, we have then to consider the accuracy of the reference itself. For the GPS-89, deviations appear in the 12th digit.

By measuring for quite a long time we can improve the resolution and reduce the uncertainty of the measurement even more. The other sources of errors in the measurement, like timebase oscillator stability and trigger errors due to noise, are negligible compared to the resolution of the TIE measurement.

Conclusion

By utilizing a high-resolution timer/counter to measure the beat frequency generated by two nominally equal frequencies, we can calibrate frequency with a very high degree of accuracy. The condition is, of course, that we have an extremely accurate reference, e. g. a Cesium reference or a GPS-controlled Rubidium standard.

The combination of the frequency reference GPS-89, Figure 5, and the timer/counter CNT-81, Figure 6, from Pendulum Instruments, is a very powerful package for calibrating the most usual reference frequencies, e. g. 10, 5 and 2.048 MHz. Furthermore, the reference GPS-89 has a programmable reference output where you can set an arbitrary reference frequency (the period time is set as N x 100 ns).

The counter CNT-81 is the fastest on the market and has also the highest resolution. When measuring frequency by means of the phase comparison method, the CNT-81 reaches a given level of accuracy, for instance 12 digits, 15 times faster than the most usual timer/counter on the market.



Figure 5. Frequency Reference GPS-89



Figure 6. Timer/Counter CNT-81



Basics in Brief – Timebase Oscillator

Internal References

The timebase oscillator of a counter is a built-in frequency reference, most often designed as a crystal oscillator, with varying degrees of accuracy:

- UCXO = Un-Compensated X-tal Oscillator (standard)
- TCXO = Temperature Compensated X-tal Osc.
- OCXO = Oven Controlled X-tal Oscillator

Where the utmost performance characteristics are required we can also see built-in *Rubidium oscillators*, which then utilize the resonance properties of the Rubidium atom to give extremely good frequency stability.

A built-in timebase oscillator in a counter must be calibrated and, if need be, adjusted regularly, typically once a year, to compensate for the so-called aging of the oscillator, i. e. long-term drift. Furthermore, variations of the ambient temperature affect the oscillator frequency.

A counter can have a display with 10-12 digits, but depending on the type of timebase oscillator, a major or a minor part of these may be reliable. Typical values for use in normal room temperature and with 1-year calibration interval are:

- UCXO: 5-6 reliable digits
- TCXO: 6-7 reliable digits
- OCXO: 7-9 reliable digits
- Rubidium: 10-11 reliable digits

In principle a newly calibrated timebase oscillator belongs to the upper part of the interval.

External References

For even higher stability we have to use ultra-stable external frequency references, e. g. Cesium standards or GPS-controlled references. The latter lack aging, in principle, since the built-in local oscillator is locked to the Cesium standards in the GPS satellites. However, the locking process causes increased short-term instability. The frequency stability that can be 1×10^{-12} over 24 h can be 100 – 1000 times worse over short times, e. g. 1 s – 10 s, normal measuring times in frequency counters. Note that this instability concerns locking a local oven oscillator. If we lock a local Rubidium oscillator (like the GPS-89 from Pendulum, for instance), the locking process is not measurable, but we have a frequency reference comparable to the Cesium reference at a fraction of the cost. See Figure 7.

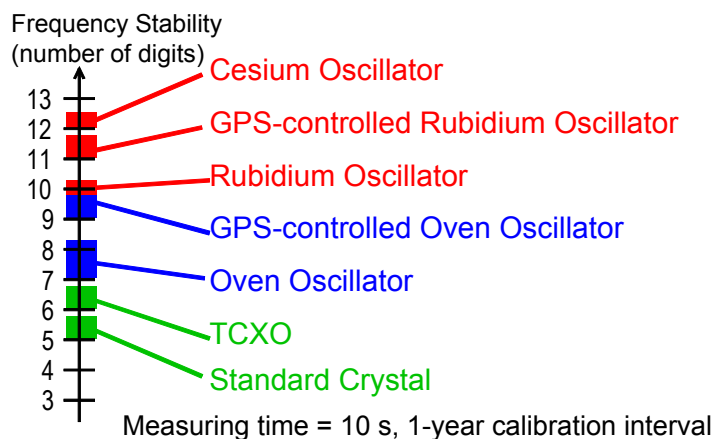

Figure 7. A GPS-controlled Rubidium oscillator gives a level of accuracy approaching that of a Cesium standard but at a fraction of its cost.



Basics in Brief – Resolution

Depending on the design of the counter with conventional, reciprocal or interpolating measurement technique, the measurements will have low or high resolution.

Conventional frequency counting does not exist any more in modern counters. With this method the number of cycles at the input was counted during a fixed time, usually one second. The resolution of the measurement is then one cycle per second (c/s), i. e. 1 Hz. The relative resolution then depends on what frequency we are measuring. For 100 Hz, for instance, the relative resolution is 1 Hz / 100 Hz or "2 digits" (10^{-2}). For 10 MHz the relative resolution is 1 Hz / 10 MHz or "7 digits" (10^{-7}).

Reciprocal counters measure the period time of the input signal by counting clock pulses (N_{CP}) from a 10 MHz reference clock for an integer number of periods (N_P) of the input signal. Usually we measure during a measuring time of 1 s. After that the period time T is calculated:

$$T = N_{CP}/N_P \times 100 \text{ ns}$$

and the frequency f is the reciprocal of T:

$$f = 1/ T = N_P/N_{CP} \times 10 \text{ MHz}$$

The resolution with this method is always 7 digits for 1 s measuring time (100 ns resolution in 1 s), independent of the frequency.

Interpolating counters are basically reciprocal counters with improved time measurement resolution. Not only the integer number of clock pulses given by the time measurement is counted, but also the incomplete parts of the clock pulses at the beginning and at the end of the time measurement are calculated by means of interpolation. The result for modern counters is an improvement of the resolution by 100-400 times. Time measurement can then be made with a resolution of hundreds of ps.

In this way modern interpolating counters will attain a resolution of 10 digits in 1 s measuring time. For commercially available counters, the absolutely highest resolution on the market today is found in the CNT-81 from Pendulum Instruments, having a resolution of 50 ps or 11 digits for frequency measurements with 1 s measuring time.

Independent of the design of the counter (conventional, reciprocal or interpolating), it is true that resolution is proportional to measuring time. If we increase the measuring time from 1 s to 10 s, we will get another digit in the actual resolution. And vice versa, if we decrease the measuring time from 1 s to 100 ms we will get one digit less. Most counters on the market cannot measure with longer measuring times than 10 s, with a few exceptions e.g. the CNT-80 family from Pendulum Instruments, capable of measuring up to 400 s. See Figure 8.

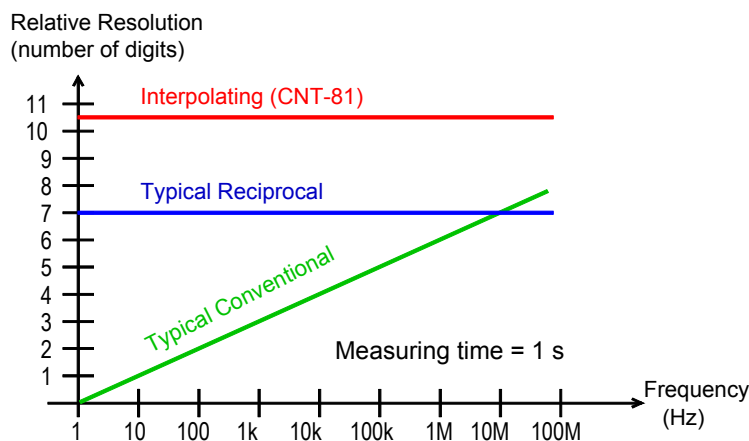

Figure 8. Resolution is proportional to measuring time. Counters belonging to the CNT-80 family can measure up to 400 s.